

AITC TECHNICAL NOTE 12

DESIGNING STRUCTURAL GLUED LAMINATED TIMBER FOR PERMANENCE

October 2002

AMERICAN INSTITUTE OF TIMBER CONSTRUCTION

7012 South Revere Parkway, Suite 140

Phone 303-792-9559 • Fax 303-792-0669

• Email: info@aitc-glulam.org • Website: www.aitc-glulam.org

Properly designed and constructed wood structures have performed well in service for centuries. Norwegian stave churches, built in the 12th and 13th centuries A. D., still stand as a tribute to the durability of properly designed wood structures. The key to the durability of these structures is found in design details which keep the wood dry.¹⁰

With durability comparable to sawn timbers, glued laminated timbers also perform well with proper design. Early glued laminated wood beams and arches, built in Europe shortly after the turn of the century, and in the United States in the 1930's are still in use, today.⁸

The permanence of timber structures is best attained by keeping the wood dry. Wood kept below 20% moisture and protected from insect attack will last indefinitely. Proper design includes:

- protecting wood from exposure to precipitation.
- joint details to prevent moisture entrapment.
- adequate flashings to shed water.
- a well-drained building site.
- control of humidity.
- proper vapor or moisture barriers.
- use of decay resistant species or preservatively treated wood when appropriate.

When moisture content exceeds 20%, wood is susceptible to decay. For conditions of high moisture content (>20%), the use of preservatively treated wood or heartwood of a naturally decay resistant species is recommended to extend the life of the structure. **Table 1** shows the equilibrium moisture content for wood at various temperatures and relative humidities.

DECAY

Designing wood structures for permanence requires an understanding of decay. Wood decay is caused by fungi that use wood as a food source.^{7,11} Fungi develop and grow from microscopic spores that are present in wood, but are generally dormant. When conditions are right, the fungi become active and convert wood substance into food. Decay fungi can be controlled by depriving them of one of four basic biological needs:^{6,7,11}

1. Air
2. Proper temperatures (32 °F – 100 °F)
3. Moisture
4. Food

Table 1. Equilibrium moisture content of wood at various temperatures and relative humidities.

| Temperature | | Relative Humidity | | | | | | | | | | | | | | | | | | |
|-------------|------|-------------------|-----|-----|-----|-----|-----|-----|-----|-----|-----|------|------|------|------|------|------|------|------|------|
| °F | °C | 5% | 10% | 15% | 20% | 25% | 30% | 35% | 40% | 45% | 50% | 55% | 60% | 65% | 70% | 75% | 80% | 85% | 90% | 95% |
| 30 | -1.1 | 1.4 | 2.6 | 3.7 | 4.6 | 5.5 | 6.3 | 7.1 | 7.9 | 8.7 | 9.5 | 10.4 | 11.3 | 12.4 | 13.6 | 14.9 | 16.5 | 18.5 | 21.0 | 24.3 |
| 40 | 4.4 | 1.4 | 2.6 | 3.7 | 4.6 | 5.5 | 6.3 | 7.1 | 7.9 | 8.7 | 9.5 | 10.4 | 11.3 | 12.4 | 13.5 | 14.9 | 16.5 | 18.5 | 21.0 | 24.4 |
| 50 | 10.0 | 1.4 | 2.6 | 3.6 | 4.6 | 5.5 | 6.3 | 7.1 | 7.9 | 8.7 | 9.5 | 10.3 | 11.2 | 12.3 | 13.4 | 14.8 | 16.4 | 18.4 | 20.9 | 24.3 |
| 60 | 15.6 | 1.3 | 2.5 | 3.6 | 4.6 | 5.4 | 6.3 | 7.0 | 7.8 | 8.6 | 9.4 | 10.2 | 11.1 | 12.1 | 13.3 | 14.6 | 16.2 | 18.2 | 20.7 | 24.1 |
| 70 | 21.1 | 1.3 | 2.5 | 3.5 | 4.5 | 5.4 | 6.2 | 6.9 | 7.7 | 8.5 | 9.2 | 10.1 | 11.0 | 12.0 | 13.1 | 14.4 | 16.0 | 18.0 | 20.5 | 23.9 |
| 80 | 26.7 | 1.3 | 2.4 | 3.5 | 4.4 | 5.3 | 6.1 | 6.8 | 7.6 | 8.3 | 9.1 | 9.9 | 10.8 | 11.8 | 12.9 | 14.2 | 15.7 | 17.7 | 20.2 | 23.6 |
| 90 | 32.2 | 1.2 | 2.4 | 3.4 | 4.3 | 5.1 | 5.9 | 6.7 | 7.4 | 8.1 | 8.9 | 9.7 | 10.6 | 11.5 | 12.6 | 13.9 | 15.4 | 17.4 | 19.9 | 23.3 |
| 100 | 37.8 | 1.2 | 2.3 | 3.3 | 4.2 | 5.0 | 5.8 | 6.5 | 7.2 | 7.9 | 8.7 | 9.5 | 10.3 | 11.2 | 12.3 | 13.6 | 15.1 | 17.0 | 19.5 | 22.9 |
| 110 | 43.3 | 1.1 | 2.2 | 3.2 | 4.0 | 4.9 | 5.6 | 6.3 | 7.0 | 7.7 | 8.5 | 9.2 | 10.0 | 11.0 | 12.0 | 13.2 | 14.7 | 16.6 | 19.1 | 22.5 |
| 120 | 48.9 | 1.1 | 2.1 | 3.0 | 3.9 | 4.7 | 5.4 | 6.1 | 6.8 | 7.5 | 8.2 | 8.9 | 9.8 | 10.7 | 11.7 | 12.9 | 14.4 | 16.2 | 18.6 | 22.0 |
| 130 | 54.4 | 1.0 | 2.0 | 2.9 | 3.7 | 4.5 | 5.2 | 5.9 | 6.6 | 7.3 | 7.9 | 8.7 | 9.5 | 10.3 | 11.3 | 12.5 | 14.0 | 15.8 | 18.2 | 21.5 |
| 140 | 60.0 | 0.9 | 1.9 | 2.8 | 3.6 | 4.3 | 5.0 | 5.7 | 6.3 | 7.0 | 7.7 | 8.4 | 9.1 | 10.0 | 11.0 | 12.2 | 13.6 | 15.4 | 17.7 | 21.0 |
| 150 | 65.6 | 0.9 | 1.8 | 2.6 | 3.4 | 4.1 | 4.8 | 5.5 | 6.1 | 6.7 | 7.4 | 8.1 | 8.8 | 9.7 | 10.6 | 11.8 | 13.2 | 14.9 | 17.2 | 20.5 |
| 160 | 71.1 | 0.8 | 1.6 | 2.4 | 3.2 | 3.9 | 4.6 | 5.2 | 5.8 | 6.5 | 7.1 | 7.8 | 8.5 | 9.3 | 10.3 | 11.4 | 12.7 | 14.4 | 16.7 | 19.9 |

Values were calculated using Equation 3-3, Wood Handbook: Wood as an Engineering Material, 1999, FPL-GTR-113.

Air Elimination and Temperature Control

Decay fungi can be deprived of air by submerging wood in water or through continual sprinkling. These methods are commonly used to prevent fungal growth in green logs prior to milling. For typical uses, however, these methods are impractical. Likewise, temperature control is not normally a viable option to prevent decay, because the temperatures required for fungal growth coincide with the range of temperatures suitable for humans. Cold storage facilities would be an exception to this rule.

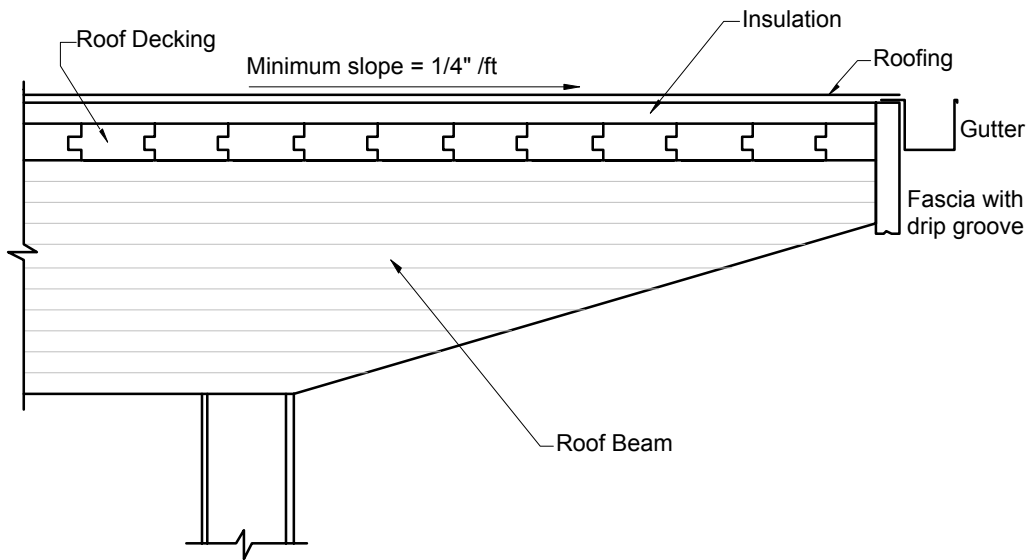

Figure 1. Beam is protected from weather by roof and fascia, preservative treatment not required.

Moisture Control

The most effective way to eliminate decay in structures is by keeping wood dry. Wood artifacts found in the pyramids of Egypt were discovered sound after thousands of years, because they remained dry.^{6,11} Whenever possible wood should be protected from exposure to the weather, such as by covering with a roof (**Figure 1**). For most circumstances, this is all that is needed to prevent decay. Typical indoor equilibrium moisture content in well-ventilated buildings is shown in **Figure 2**.

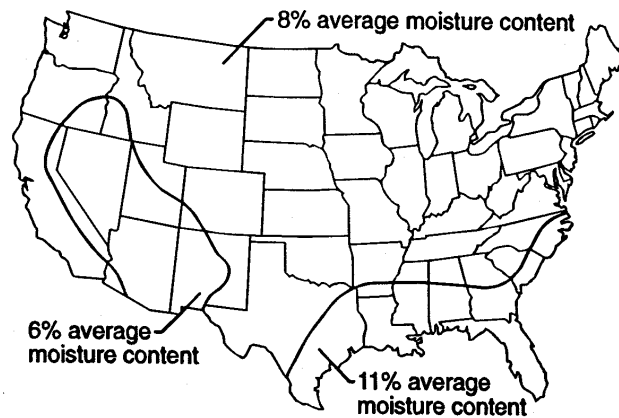

Figure 2. U.S. indoor equilibrium moisture content. (Excerpted from *Wood Handbook* (USDA, 1999))

Wood should not be placed directly in contact with masonry or concrete. Protection may be provided by the use of ventilated air spaces, vapor barriers or metal base plates or shoes (**Figure 3**). Additional design details for the prevention of decay can be found in *AITC 104-84 Typical Construction Details*¹ and in the *Timber Construction Manual*.³

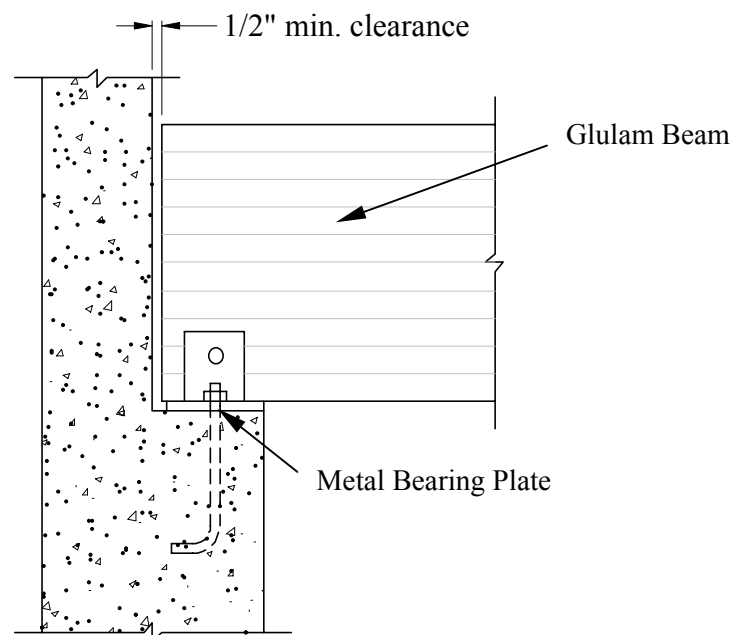

Figure 3. Beam should not be placed in direct contact with concrete or masonry.

Structures housing swimming pools, ice skating rinks, wet process industries, etc. require special attention. Because these uses tend to cause high relative humidity, wood may be subject to decay. If adequate ventilation, capable of reducing the relative humidity to acceptable levels (**Table 1**), is not provided, preservative treated wood or heartwood of a naturally decay resistant species should be used.

Elimination of Food Source

The final means by which decay can be prevented is through elimination of the food source. This is accomplished by rendering the wood substance inedible to decay fungi. The heartwood of certain durable species such as cedar and redwood contain extractives which make the wood decay resistant. For non-durable species of wood, treatment with preservative chemicals can be used to prevent decay. Required retention and penetration of preservative are detailed in *AITC 109-98 Standard for Preservative Treatment of Structural Glued Laminated Timber*.²

WHERE PRESERVATIVE TREATMENT OR A DECAY RESISTANT SPECIES IS REQUIRED

Where moisture content of the wood will exceed 20%, preservative treated wood or the heartwood of a decay resistant species must be used. Any wood exposed to the weather should be of a naturally durable species or preservative treated. Example structures include: bridges, piers, wharves, towers and utility structures. Similarly, if wood is exposed on the outside of a building where there is no protection from roof, eaves, overhangs or similar covering, decay resistance is required (**Figure 4**). It should be noted that use of preservative treated wood or heartwood of a decay resistant species will not prevent checking or other forms of surface degradation due to weathering. Proper coatings, adequately maintained, can reduce the aesthetic impact of weathering on an exposed member.

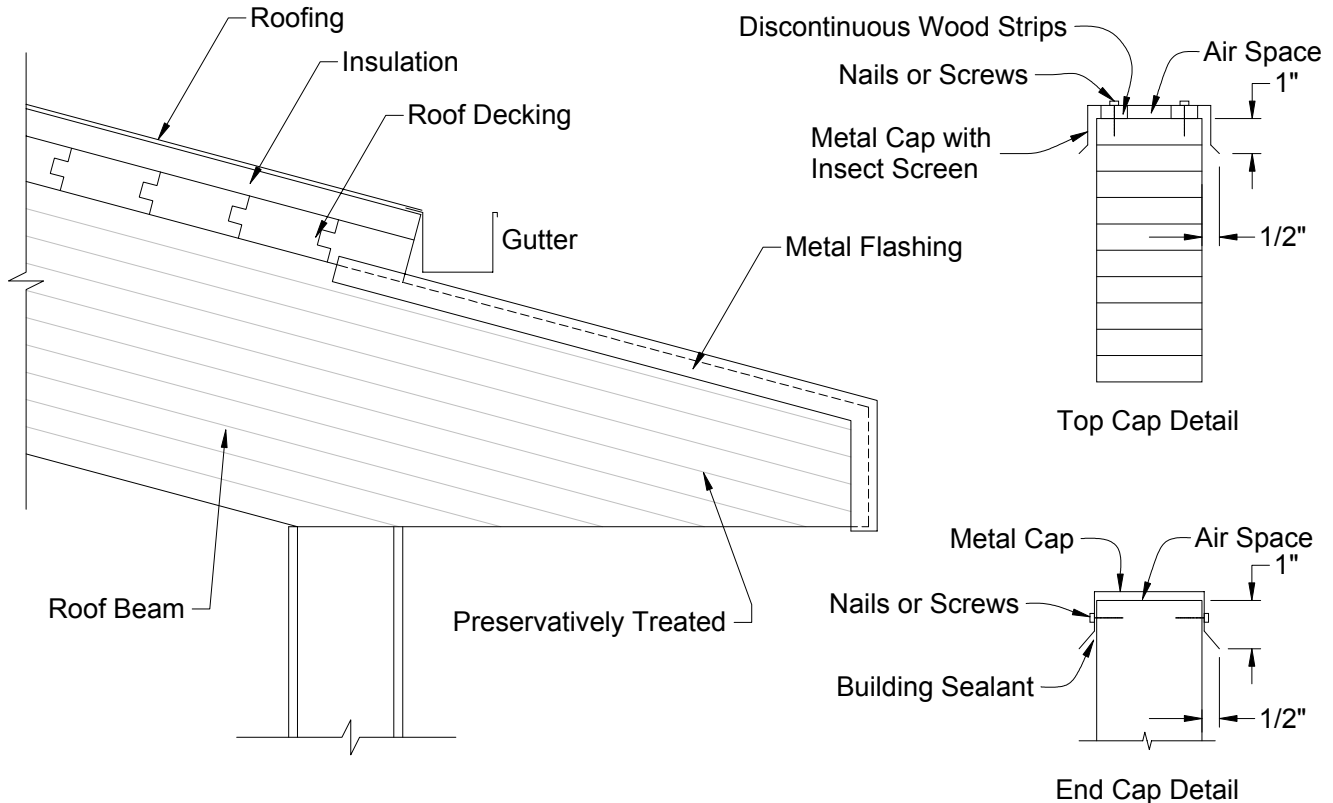

Figure 4. Preservative-treated beam projecting from roof with top and end covered by metal flashing.

PRESERVATIVE TREATMENTS

Preservative treatment for glued laminated timber can be applied to the lumber prior to laminating or to the laminated member after gluing. Preservative treatment of glued laminated timber can be divided into three general categories:

- a) treatments of members after laminating with creosote or pentachlorophenol (penta) in heavy oil;
- b) treatments of members after laminating with penta in light solvent; and
- c) treatments of laminations prior to laminating with penta in light solvent or waterborne preservative.

Treatments in category a) are effective for glued laminated timbers exposed to the most severe conditions such as bridges, piers and wharves, towers and electric utility structures; or in direct contact with the ground or with water. The oil in the treatments minimizes moisture movement into the wood. Such treatments are oily and are generally unsuitable for human contact. Penta in heavy oil is not recommended for contact with salt water. Treatments in categories b) and c) have proven effective for architectural applications but they now have limited availability in some geographical areas.

To be reliable, preservatives must be applied by pressure methods, following *American Wood Preservers' Association Standard C28-99*.⁴ All fabrication, cutting and boring of timbers should be done prior to pressure treatment whenever possible. When field or other fabrication is required after treatment, the cuts or bored holes should have additional treatment applied in accordance with *American Wood Preservers' Association Standard M4-99*.⁵

REFERENCES

1. AITC. 1984. AITC 104-84, Typical Construction Details. American Institute of Timber Construction. Englewood, Colorado.
2. AITC. 1998. AITC 109-98, Standard for Preservative Treatment of Structural Glued Laminated Timber. American Institute of Timber Construction. Englewood, Colorado.
3. AITC. 1994. Timber Construction Manual. 4th ed. John Wiley & Sons. New York, New York.
4. AWPA. 1999. AWPA C28-99, Standard for Preservative Treatment of Structural Glued Laminated Members and Laminations Before Gluing of Southern Pine, Coastal Douglas-fir, Hem-fir, and Western Hemlock by Pressure Processes. American Wood Preservers' Association. Woodstock, Maryland.
5. AWPA. 1999. AWPA M4-99, Standard for the Care of Preservative Treated Wood Products. American Wood Preservers' Association. Woodstock, Maryland.
6. Little, R. J., F. G. Wagner, and H. O. Beals. 1978. Preservative Treatment of Posts, Timber, and Lumber. General Report SA-GR2. USDA Forest Service. Atlanta, Georgia.
7. Panshin, A. J. and Carl de Zeeuw. Textbook of Wood Technology. 4th ed. McGraw-Hill, Inc. New York, New York.
8. Rhude, A. J. 1996. Structural Glued Laminated Timber: History of its Origins and Early Development. Forest Products Journal. 46(1):15-22.
9. USDA. 1999. Wood Handbook-Wood as an Engineering Material. General Technical Report FPL-GTR-113. USDA Forest Service. Forest Products Laboratory. Madison, Wisconsin.
10. Valebrokk, E. and T. Thiis-Evensen. 1997. Norway's Stave Churches: Architecture, History and Legends. 3rd ed. New Interlitho. Milan, Italy.
11. Wilkinson, J. G. 1979. Industrial Timber Preservation. Associated Business Press. London, England.